

RULA

AGRI

RULA-AGRI

CONVENTIONAL CAMELBACK PLANTER



info@rula-agri.co.za
www.rula-agri.co.za
+27 (0) 11 795 1040

CONVENTIONAL PLANTER

CONTACT US TODAY

info@rula-agri.co.za
www.rula-agri.co.za
+27(0) 11 795 1040



IN-HOUSE DEVELOPED DOWN-FORCE / UP-FORCE

The DF / UF system is controlled from a cab mounted touch screen with in-time adjustment and data display.

The cylinder can also be replaced with a mechanical spring which can also act as a mechanical down/up force on your seeding unit. The springs offer an easy roll over adjustment of the down/up force area.

SEEDING

70 l seed hoppers with steel lids as standard with the option of a central seeding alternative.

METERING

Use of the popular Precision vSet 2 seed meter along with the Bullseye seed tube ensures accuracy and precision.

CLOSING SYSTEMS

Choose from our various closing wheel combinations.

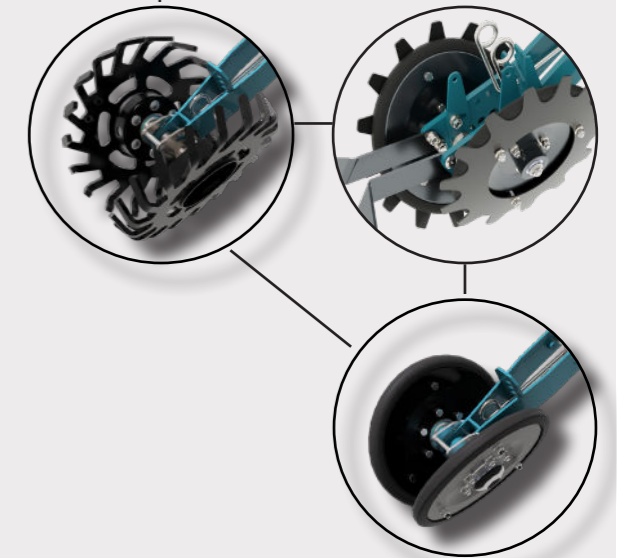

SEED DISCS

Seed discs (Ø450) are fitted with a leading edge at 8.5° furrow opening angle.

WHEEL SPACING

Adjustable wheel spacing enables a wide & narrow rolling configuration.

DEPTH ADJUSTMENT

A quick planting depth adjustment.

FERTILIZER CUTTING COULTER

Coulter is fitted with a spring-loaded cutting coulter (Ø560) and can be adjusted with ease (Different coulter options are available).

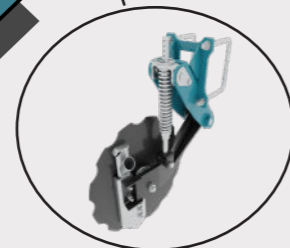
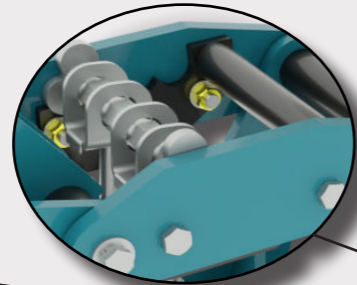
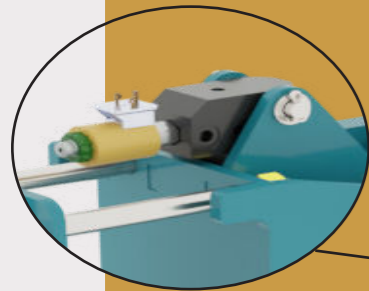
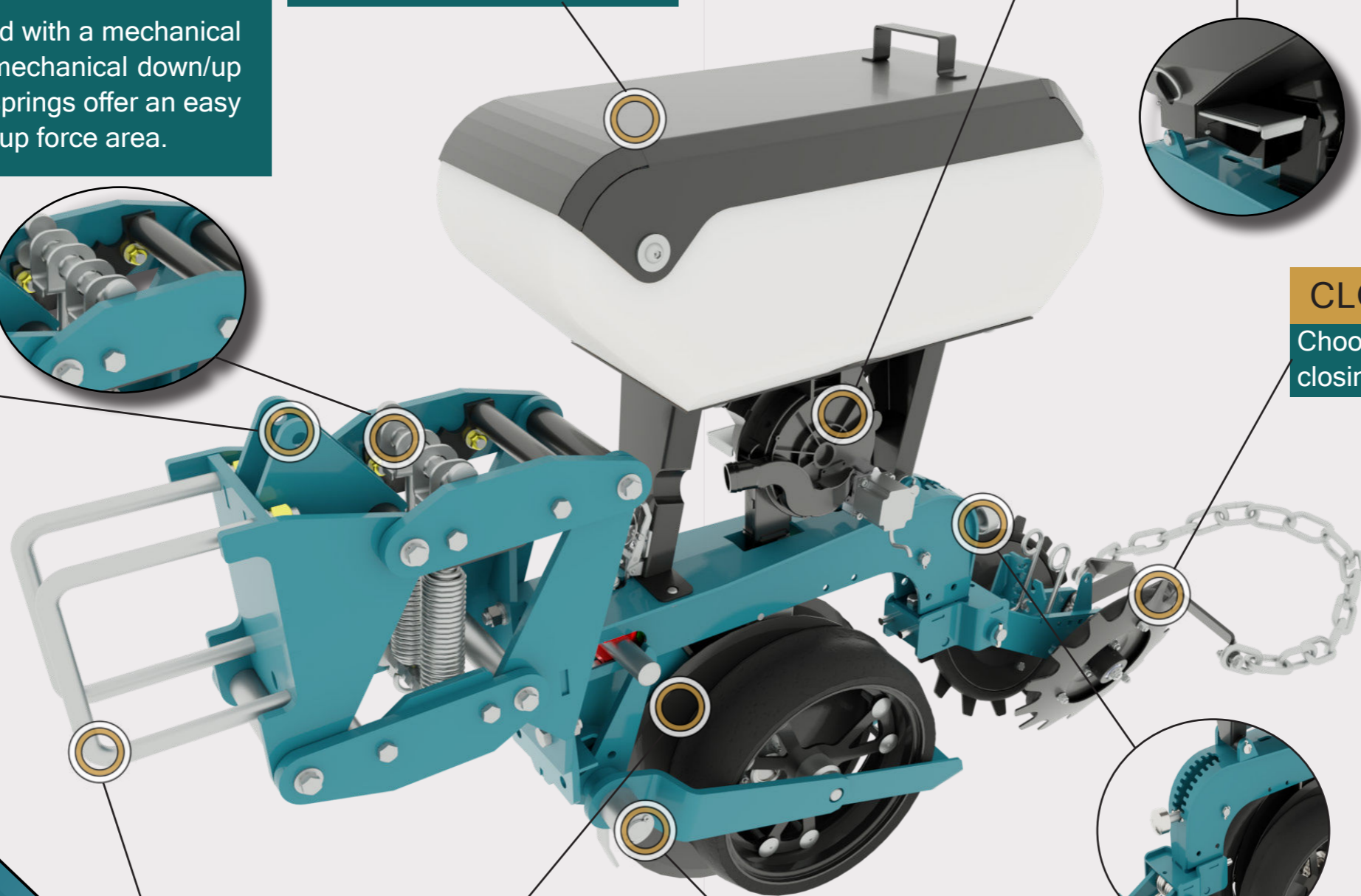

RULA
AGRI

DESIGNED AND
MANUFACTURED IN
SOUTH AFRICA



SERVICES

- Mechanical Design
- Structural Design
- Manufacturing
- Finite Element Analysis
- Bulk Material Handling
- Flow Dynamics

Planter Implement Configurations				
Number of Rows Available:				
6	8	10	12	16
Kilo Watts Required (12 kW per Unit):				
72 kW	96 kW	120 kW	144 kW	192 kW
Row Spacing:				
514	762	914	T/L	
Tank Capacities: (Liquid & Granular Fertiliser)				
2000 ℓ	3500 ℓ	4000 ℓ	6000 ℓ	8000 ℓ

Rula-Agri specialises in custom designs. Our wide range of engineering capabilities ensure that we are able to provide you with exactly what you and your farm require.
CONTACT US TODAY!

