

**RULA**

**AGRI**

# **RULA-AGRI**

## **FERTO 120**



info@rula-agri.co.za  
www.rula-agri.co.za  
+27 (0) 11 795 1040

UV resistant polyethylene tanks

Tarpaulin rain cover

Choice of a conveyor, auger or both



Swivel A-frame that allows fine adjustments during load-out

Articulating Ackermann steering

A choice of super single road tyres or high flotation tyres

Available with Load Cells

**RULA**

**AGRI**



DESIGNED AND MANUFACTURED IN SOUTH AFRICA



Model	FERTO 120
Capacity	11 000L (2 x 5500L Tanks)
Transport Length	8.6m
Transport Height	3.3m
Transport Width	2.9m
Tyres	385/65 R22.5 or 400/60 R22.5
Discharge Height	3.55m
Attachment	Auger/Conveyor
Discharge Capacity (Ø200 mm Auger - Fertilizer)	±400kg/min @ ±40°
Discharge Capacity (300 mm Conveyor)	±900kg/min @ ±40°

# FERTO 120

## Multi-Function Chaser Bin

CONTACT US TODAY

info@rula-agri.co.za  
www.rula-agri.co.za  
+27(0) 11 795 1040

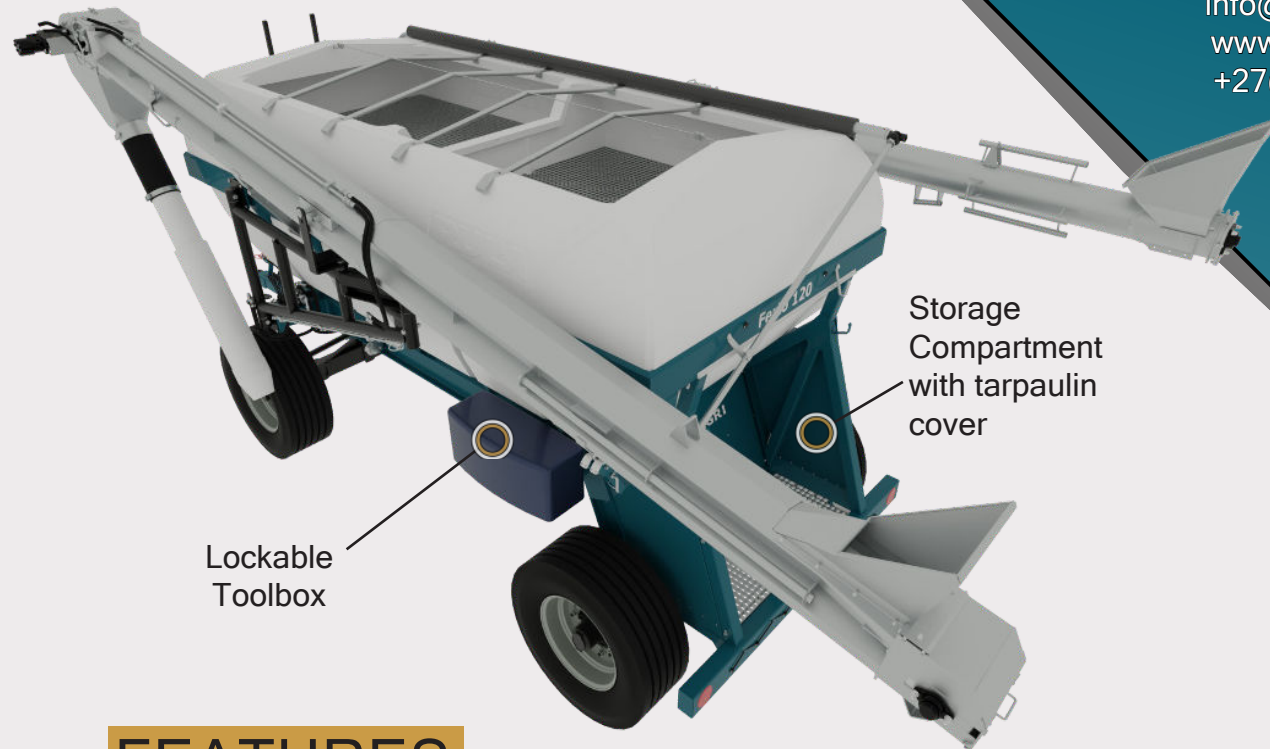

Lockable  
Toolbox

Storage  
Compartment  
with tarpaulin  
cover

## FEATURES

The new Rula-Agri Ferto 120 will put the productivity of your farm into the next gear with the following features:

- One operator needed to fill up or empty the trailer.
- Ideal for filling up a pre-planter with fertiliser or a planter with seed at rates of up to 900kg/min.
- Can be equipped with a 7m auger or a 6.5m cleated conveyor.
- Two hydraulically controlled, discharge sluices at the bottom of the tank.
- Optional extras: Load-Cell or Hydraulic Brake System

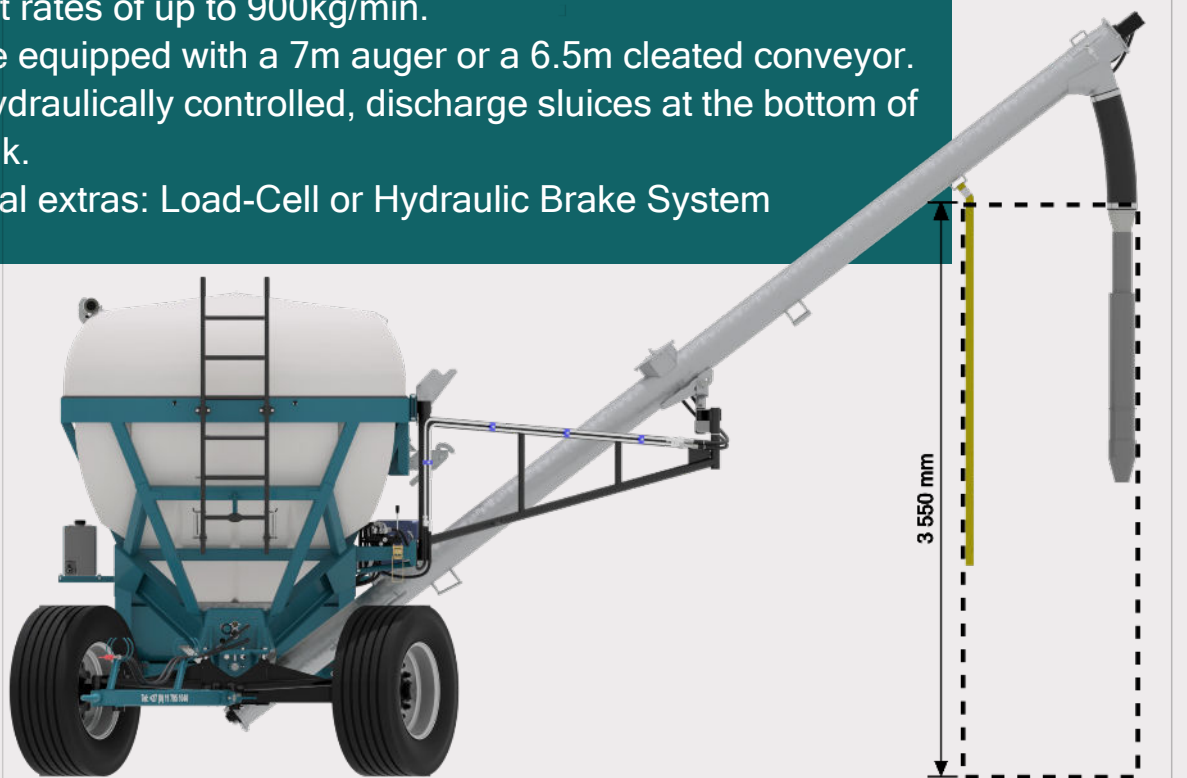

3 550 mm

## SERVICES

Mechanical Design

Structural Design

Manufacturing

Finite Element Analysis

Bulk Material Handling

Flow Dynamics



Rula-Agri specialises in custom designs. Our wide range of engineering capabilities ensure that we are able to provide you with exactly what you and your farm require.  
**CONTACT US TODAY!**